

CKM New FL-12 Fully Auto Finger Jointing line.

CKM[®]
Quality & Service

FL-12

Maximize Productivity !

Designed with operation convenience and economy in mind !

With CKM new generation FL-12 Fully Auto Finger Jointing Line, you can obtain a fully automatic production yet at an affordable price. Designed and engineered for high production and economy in mind, this new FL-12 is built with CKM's tradition of superior quality and performance. Minimum trouble for operations year after year. In addition, its compact construction will save your working space. The CKM FL-12 also saves your labor cost greatly by requiring only one operator to attend the machine. The entire motion cycle from initial workpiece infeed, right and left end shaping, jointing to final product outfeed are fully automatic operated. Let us show you how the FL-12 creates profits for you.

" FULLY AUTOMATIC PRODUCTION PROCESS "

LEFT END



Scoring

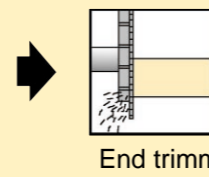

End trimming

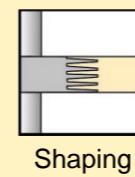

Shaping

RIGHT END

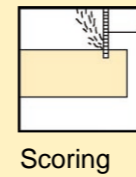

Scoring

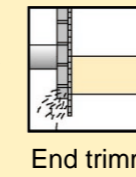

End trimming

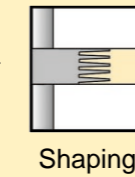

Shaping

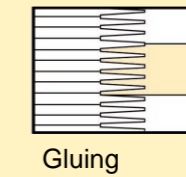

Gluing

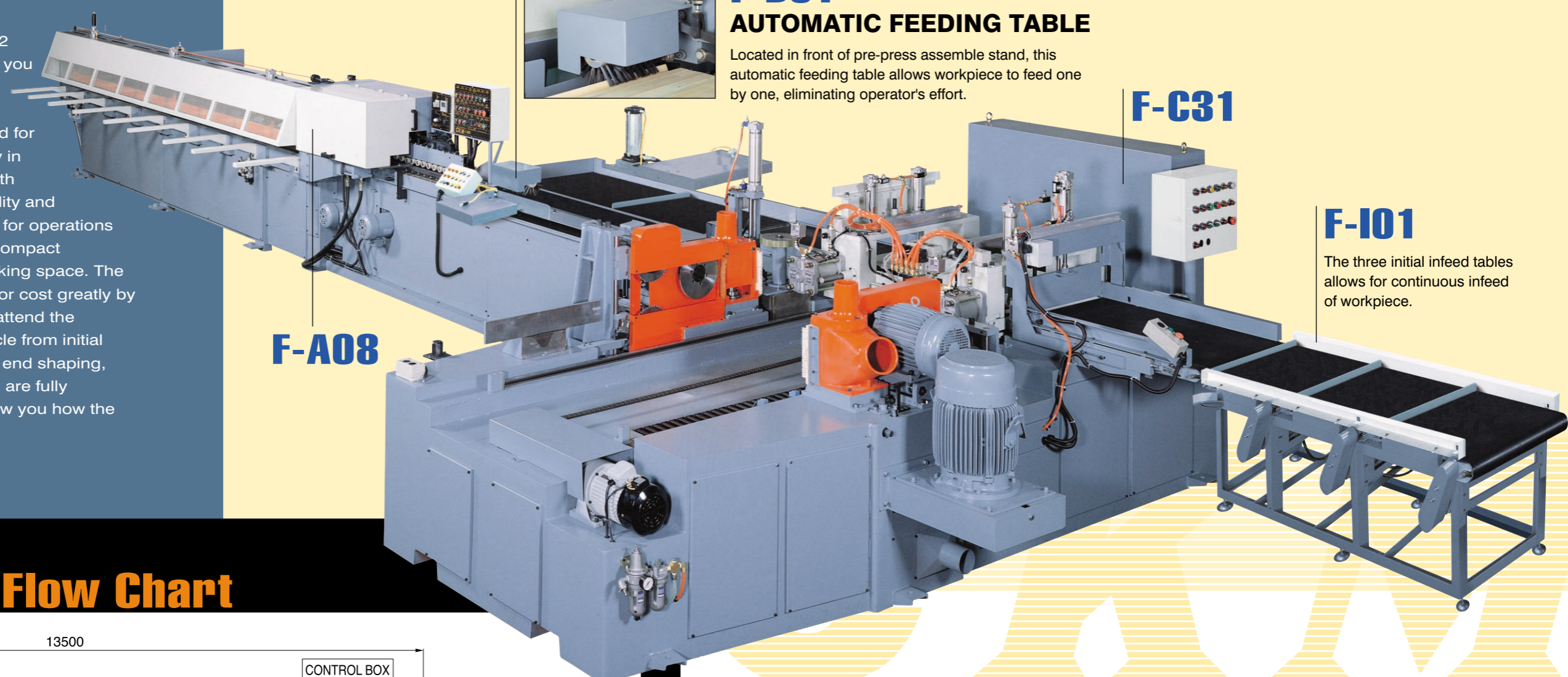

F-A08

F-D01
AUTOMATIC FEEDING TABLE

Located in front of pre-press assemble stand, this automatic feeding table allows workpiece to feed one by one, eliminating operator's effort.

F-C31

F-I01

The three initial infeed tables allows for continuous infeed of workpiece.

Production Flow Chart

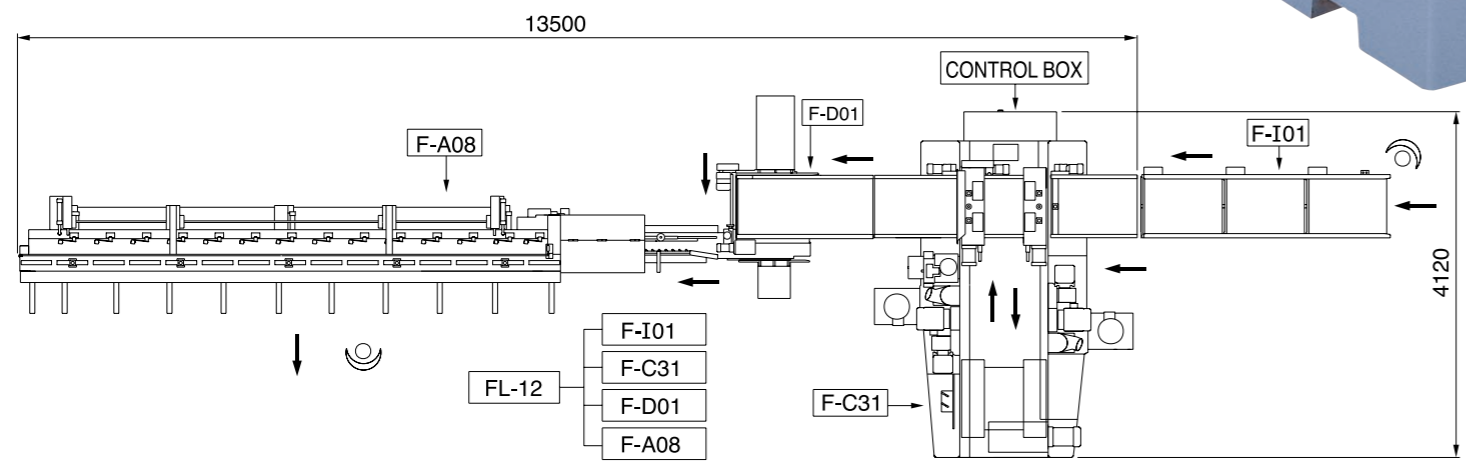

- 1** Automatic initial infeeding of workpiece.
- 2** Automatic feed table.
- 3** F-C31 performs scoring trimming and shaping on right end of workpiece.
- 4** Table moves from right to left side.
- 5** F-C31 performs scoring trimming shaping and gluing on left end of workpiece.
- 6** Workpieces feed directly onto F-D01 hand feeding table.
- 7** Operator shifts workpieces onto the infeed conveyor of assemble press.
- 8** Workpieces travel forward for cutting-to-length.
- 9** Finger assembly is performed by a powerful hydraulic system.
- 10** Final products out-feed on staying platform.

F-C31 FINGER SHAPER

Max available width sorking table	650mm
Range of material length	150~1000mm
Range of material width	30~160mm
Trimming saw speed	2800RPM/50HZ, 3400RPM/60HZ
Finger cutter speed	5000RPM
Scoring saw speed	2800RPM/50HZ, 3400RPM/60HZ

POWER REQUIRED

Table drive motor	2HP
For conveyor	1/2HPx3
For scoring saw	1HPx3
For trimming saw	10HPx2
For finger cutter	20HPx2
Dust outlet diameter	6"x2, 4"x4
Machine dimension(LxWxH)	3750x3070x1650mm
Packing dimension(LxWxH)	4850x2130x1750mm

F-A08 ASSEMBLE PRESS F-A08(4.5M) F-A08(6M)

Available length of product	4.5m	6.2m
Available thickness of product	60mm	60mm
Available width of product	160mm	160mm
Finger assembly pressure	0-150kg/cm ²	0-150kg/cm ²
Feeding speed	80m/min	80m/min
Capacity 6m length product		5PCS
Capacity 4.5m length product	4-6PCS	
Hydraulic power unit	5HP	5HP

POWER REQUIRED

For feeding	2HPx1, 3HPx1	2HPx1, 3HPx1
For sizing saw	5HP	5HP
Dust outlet diameter	4"x1	4"x1
Machine dimension(LxWxH)	8770x1380x1350mm	10290x1380x1350mm
Packing dimension(LxWxH)	5800x1480x1460mm	7300x1480x1460mm
Packing dimension(LxWxH)	3270x630x1180mm	3270x630x1180mm

F-D01 AUTOMATIC FEEDING TABLE

Auto feeding table	650 mm
Range of materid length	100-1000 mm
Range of material width	30-160 mm
Motor	1 HP
Brush wheel drive motor	1/8 HP
Machine dimension (LxWxH)	1440x2660x1330 mm
Packing dimension (LxWxH)	1540x2760x1430 mm

F-I01 HAND FEEDING TABLE

Auto Feeding Table	650 mm
Feed drive motor	1 HPx3
Machine dimension (LxWxH)	3190x870x970 mm
Packing dimensions (LxWxH)	3300x970x1070 mm

★ All specifications, dimensions and design characteristics are subject to change without prior notice.

STANDARD ACCESSORIES

- Trimming sawblade 2 pcs.
- Hocking sawblade 2 pcs.
- Scoring sawblade 3 pcs.
- Cutter presetter 1 set.

OPTIONAL EQUIPMENT

- Shaper cutter grinder.

CKM[®]
Quality & Service

CHENG KUANG WOOD MACHINERY WORKS CO., LTD.

NO.387, Shoei Yuan Rd., Feng Yuan, Taichung, 420, Taiwan.

Tel: 886-4-2524 1105~7 Fax: 886-4-2527 5507

http://www.ckmtw.com.tw E-mail:ckmmail@ckmtw.com.tw

Fully Auto Finger Jointing Line

NEW CKM FL-12

Cut Costs !

Upgrade Productivity !

- Fully automatic operation.
- High production at an affordable price.
- Requires only one operator to attend the machine.
- Compact construction for space saving.

FL-12

Now, you can afford a fully automatic finger jointing line for profitable production.

Sustainability NO.2009202 Tel:04-23271907

CHENG KUANG WOOD MACHINERY WORKS CO., LTD.

CKM[®]
Quality & Service